



CS6200-EI Copper Series L3+ 10G Routing Switch

Product Overview

DCN CS6200-EI copper series switches are next-generation 10G stackable routing switches that provide fixed gigabit access and 10GE uplink ports. CS6200-EI copper switch has advanced hardware and software architecture design. These switches provide high availability, scalability, security, energy efficiency, and ease of operation with rich features such as **VSF (Virtual Switch Framework)**, IEEE 802.3at optional and redundant power supplies. It is ideal for high-density aggregation or core layer in campus networks or SMB networks.

The following models are available in the CS6200-EI copper series.

Appearance	Description
 <p>CS6200-28X-EI(R2)</p>	<ul style="list-style-type: none"> ● 20 x 10/100/1000BaseT + 4 x GE Combo (GT/SFP) + 4 x 10GE(SFP+) ● Fixed Redundant AC+AC Power supply ● 1 console, 1 USB, 1 RJ45 management port ● 1 Reset Button ● Forwarding performance: 95Mpps ● Switching capacity: 128Gbps
 <p>CS6200-28X-P-EI(R2)</p>	<ul style="list-style-type: none"> ● 20 x 10/100/1000BaseT + 4 x GE Combo (GT/SFP) + 4 x 10GE(SFP+) ● Fixed Single AC Power supply ● 1 console, 1 USB, 1 RJ45 management port ● 1 Reset Button ● PoE+ up to 370W ● Forwarding performance: 95Mpps ● Switching capacity: 128Gbps
 <p>CS6200-52X-EI</p>	<ul style="list-style-type: none"> ● 48 x 10/100/1000BaseT + 4 x 10GE(SFP+) ● Fixed Redundant AC+AC Power supply ● 1 console, 1 USB, 1 RJ45 management port ● 1 Reset Button ● Forwarding performance: 131Mpps ● Switching capacity: 176Gbps

Key Features and Highlights

Performance and Scalability

With high switching capacity, CS6200-EI copper series support wire-speed L2/L3 forwarding and high routing performance for IPv4 and IPv6 protocols.

The 10 Gigabit Ethernet connectivity of CS6200-EI copper is accomplished via a hot-pluggable 10 Gigabit SFP+ transceiver which supports distance up to 300 meters over multimode fiber and 10 to 40km over single-mode fiber (The distance depends on the optical module chosen).

VSF (Virtual Switch Framework)

Virtual Switch Framework can virtualize multiple DCN switches into one logical device, achieving the sharing of information and data tables between different switches. The performance and ports density of the virtualized device is greatly enlarged by times under VSF. VSF also simplifies management work for the network administrator and provides more reliability.

Rich L3 Features

CS6200-EI copper series delivers high-performance, hardware-based IP routing. RIP, OSPF, and BGP provide dynamic routing by exchanging routing information with other Layer 3 switches and routers. With the CS6200-EI copper series, customers could easily achieve a Policy-based Route (PBR), which is important when they need a multi exit application.

Strong Multicast

CS6200-EI copper series supports abundant multicast features. In Layer 2, such as IGMPv1/v2/v3 snooping and fast leave. L3 multicast protocols such as IGMPv1/v2/v3, PIM-DM, PIM-SM, PIM-SSM, and even MSDP. With Multicast VLAN Register (MVR), multicast receiver/sender control and illegal multicast source detect functions; the CS6200-EI copper series provides a great application experience for the customer.

Easy High-Reliability network

MRPP is a Multi-layer Ring Protection Protocol, which is DCN's private fast Ethernet ring protocol. Comparing to spanning tree protocol, it has the advantages of fast convergence, simple protocol calculation, fewer system resources cost, and so on, which can improve the reliability of Ethernet network operation.

Comprehensive QoS

With 8 queues per port, the CS6200-EI copper series enable differentiated management of up to 8 traffic types. The traffic is prioritized according to IEEE802.1p, DSCP, IP precedence, and TCP/UDP port number, giving optimal performance to real-time applications such as voice and video.

CS6200-EI copper series also supports Bi-directional rate-limiting, per port or traffic class preserves network bandwidth, and allows full control of network resources.

Enhanced Security

IEEE 802.1X port-based access control and MAC-based access control ensure all users are authorized before being granted access to the network. Ingress/Egress Access Control Lists (ACLs) can be used to restrict access to sensitive network resources by denying packets based on L2/L3/L4 headers information. And for some services that are based on time, the product can support time-based ACL to match the requirement.

Secure Shell (SSH) encrypts network management information via Telnet providing secure network management.

RADIUS Authentication enables centralized control of the switch and restricts unauthorized users from altering the configuration of the switch.

Specifications

Item	CS6200-28X-EI(R2)	CS6200-28X-P-EI(R2)	CS6200-52X-EI
Performance			
Switching Capacity	128Gbps	128Gbps	176Gbps
Forwarding Rate	95Mpps	95Mpps	131Mpps
Jumbo Frame	10K	10K	10K
MAC Address	16K	16K	16K
ARP Table	4K	4K	4K
Routing Table	13K	13K	13K
ACL Table	3K	3K	3K
L3 Interface	Max 1K	Max 1K	Max 1K
Physical			
Dimension (W*H*D)	440mm x 44mm x 320mm	440mm x 44mm x 320mm	440mm x 44mm x 320mm
Management port	1 x RJ45 Ethernet Management port		
	1x Console port		
	1x USB2.0 interface		
Relative Humidity	5%~95% non-condensing		
Temperature	Working 0°C~50°C, storage -40°C~70°C		
Power Supply	Dual AC:100~240VAC, 50~60Hz	AC:100~240VAC, 50~60Hz	Dual AC: 100~240VAC, 50~60Hz
Power Consumption	<30W	<440W	<50W
PoE	NA	IEEE 802.3af/a IEEE 802.3at Total PoE power: 375W	NA
Main Features			
L1, L2 Features	IEEE802.3(10Base-T), IEEE802.3u(100Base-TX), IEEE802.3z(1000BASE-X), IEEE802.3ab(1000Base-T), IEEE802.3ae(10GBase), IEEE802.3x, IEEE802.3ak(10GBASE-CX4), Auto MDI/MDIX		
	Port loopback detection LLDP and LLDP-MED UDLD 802.3ad LACP, max 128 group trunks with max 8 ports for each trunk LACP load balance		
	N:1 Port Mirroring RSPAN		
	IEEE802.1d(STP) IEEE802.1w(RSTP) IEEE802.1s(MSTP) Root Guard BPDU Guard BPDU Tunnel		
	802.1Q, 4K VLAN MAC VLAN, Voice VLAN, PVLAN, Protocol VLAN, Multicast VLAN QinQ, Flexible QinQ GVRP N:1 VLAN Translation Broadcast / Multicast / Unicast Storm Control		
	IGMP v1/v2/v3 Snooping and L2 Query, IGMP Proxy, ND Snooping MLDv1/v2 Snooping		
	Port Security		
	Flow Control: HOL, IEEE802.3x Bandwidth Control		

L3 Features	Static Routing, RIPv1/v2, OSPFv2, BGP4 OSPFv3, BGP4+ OSPF multiple processes LPM Routing Policy-based routing (PBR) for IPv4 and IPv6 VRRP URPF, ECMP BFD
	DVMRP, PIM-DM, PIM-SM, PIM-SSM, Anycast RP, MSDP Static Multicast Route Multicast Receive Control Illegal Multicast Source Detect
	ARP Guard, Local ARP proxy, Proxy ARP, ARP Binding, Gratuitous ARP, ARP Limit Anti ARP Cheat, Anti ARP Scan
	DNS Client, DNS Relay
	GRE Tunnel
IPv6	6 to 4 Tunnel, Configured Tunnel, ISATAP Tunnel, GRE Tunnel ICMPv6, ND, DNSv6 IPv6 LPM Routing, IPv6 Policy-based Routing (PBR) IPv6 VRRPv3, IPv6 URPF, IPv6 RA RIPng, OSPFv3, BGP4+ MLD Snooping, IPv6 Multicast VLAN MLDv1/v2, PIM-SM/DM for IPv6, IPv6 Anycast RP, IPv6 ACL, IPv6 QoS
QoS	8 Queues SP, WDRR, SWDRR Traffic Classification Based on 802.1p COS, ToS, DiffServ DSCP, ACL, port number Traffic Policing PRI Mark/Remark
ACL	IP ACL, MAC ACL, IP-MAC ACL Standard and Expanded ACL Based on source/destination IP or MAC, IP Protocol, TCP/UDP port, DSCP, ToS, IP Precedence), VLAN, Tag/Untag, CoS Redirect and Statistics Rules can be configured to port, VLAN Time Ranged ACL
Security	802.1x AAA Port, MAC-based authentication Accounting based on time length and traffic Guest VLAN and auto VLAN RADIUS for IPv4 and IPv6
	TACACS+ for IPv4 and IPv6
	MAB
DHCPv4/v6 Traffic Monitor	DHCP Server/Client for IPv4/IPv6 DHCP Relay/Option 82 DHCP Snooping/Option 82
Traffic Monitor	sFlow Traffic Analysis
Security Network Management	CLI, WEB, Telnet, SNMPv1/v2c/v3 through IPv4 and IPv6 Syslog and external Syslog Server HTTP SSL SNMP MIB, SNMP TRAP, RMON 1,2,3,9 FTP/TFTP SNTP/NTP Authentication by Radius/TACACS SSH v1/v2 Dual firmware images/ Configuration files 802.3ah OAM, 802.1ag OAM

Data Features	Center VSF (Virtual Switch Framework)
----------------------	---------------------------------------

Application

Deployed as aggregation switches that provide gigabit downlink and 10G uplink in a campus or enterprise network

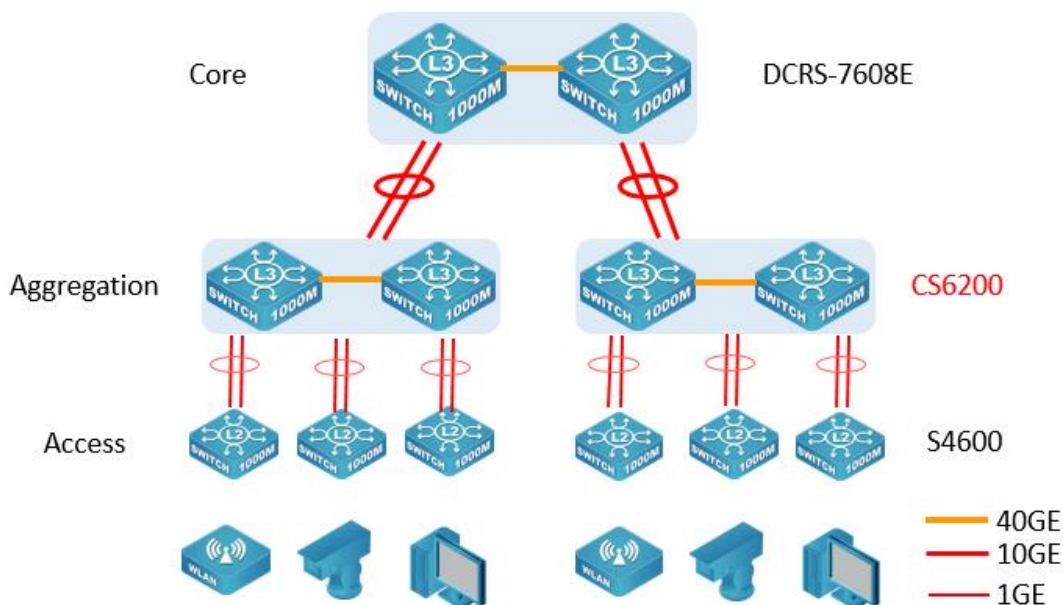

Order Information

Product	Description
CS6200-28X-EI(R2)	10G Ethernet Routing Switch, 20 x 10/100/1000BaseT + 4 x GE Combo (GT/SFP) + 4 x 10GE(SFP+), dual AC redundancy power supply.
CS6200-28X-P-EI(R2)	10G PoE Ethernet Routing Switch, 20 x 10/100/1000BaseT + 4 x GE Combo (GT/SFP) + 4 x 10GE(SFP+), One Fixed AC power supply. up to 375W for PoE
CS6200-52X-EI	10G Ethernet Routing Switch, 48 x 10/100/1000BaseT + 4 x 10GE(SFP+), dual AC redundancy power supply.)