

CS6200-8G24S2Q-EI L3+ 40G Routing Switch

Product Overview

DCN CS6200-8G24S2Q-EI is a L3 stackable routing switch with 40GE fiber uplink ports. CS6200-8G24S2Q-EI has advanced hardware and software architecture design, built-in dual redundant power supplies. CS6200 provides high availability, scalability, security, energy efficiency, and ease of operation with innovative features such as VSF (**Virtual Switch Framework**) and 3 fixed Auto-adjusted fan units. It is ideal for high-density aggregation in Enterprise networks or Campus networks. For SMB, CS6200 could be used as core switch.

Appearance	Description
 CS6200-8G24S2Q-EI	<ul style="list-style-type: none">● 8 x 10/100/1000BaseT + 24 x 10GE(SFP+) + 2 x 40GE(QSFP+)● Redundant Fixed AC+DC (48V) Power Supply● 1 console, 1 USB, 1 RJ45 management port● 1 Rest Button● Forwarding performance: 488Mpps● Switching capacity: 656Gbps

Features and Highlights

Flexible Access and Scalability

With multiple port types, CS6200-8G24S2Q support 8 ports 100M or 1000M copper access, 24 ports 1G or 10G fiber access, and 2 ports 40G fiber access.

The 40 Gigabit Ethernet connectivity of CS6200-8G24S2Q-EI is accomplished via a hot-pluggable 40 Gigabit QSFP+ transceiver which supports distance up to 300 meters over multimode fiber and 10 to 40km over single-mode fiber (The distance depends on the optical module chosen).

VSF (Virtual Switch Framework)

Virtual Switch Framework can virtualize multiple DCN switches into one logical device, achieving the sharing of information and data tables between different switches. The performance and ports density of the virtualized device is greatly enlarged by times under VSF. VSF also simplifies management work for the network administrator and provides more reliability.

Rich L3 Features

CS6200-8G24S2Q-EI delivers high-performance, hardware-based IP routing. RIP, OSPF, and BGP provide dynamic routing by exchanging routing information with other Layer 3 switches & routers. With CS6200-8G24S2Q-EI, customers could easily achieve a Policy-based Route (PBR), which is important when they need a multi exit application.

Strong Multicast

CS6200-8G24S2Q-EI supports abundant multicast features. In Layer 2, such as IGMPv1/v2/v3 snooping and fast leave. L3 multicast protocols such as IGMPv1/v2/v3, PIM-DM, PIM-SM, PIM-SSM, and even MSDP. With Multicast VLAN Register (MVR), multicast receiver/sender control and illegal multicast source detect functions; CS6200-8G24S2Q-EI provides a great application experience for the customer.

Easy High-Reliability network

MRPP is a Multi-layer Ring Protection Protocol, which is DCN's private fast Ethernet ring protocol. Comparing to spanning tree protocol, it has the advantages of fast convergence, simple protocol calculation, fewer system resources cost, and so on, which can improve the reliability of Ethernet network operation.

Comprehensive QoS

With 8 queues per port, CS6200-8G24S2Q-EI enable differentiated management of up to 8 traffic types. The traffic is prioritized according to IEEE802.1p, DSCP, IP precedence, and TCP/UDP port number, giving optimal performance to real-time applications such as voice and video.

CS6200-8G24S2Q-EI also supports Bi-directional rate-limiting, per port or traffic class preserves network bandwidth, and allows full control of network resources.

Enhanced Security

IEEE 802.1X port-based access control and MAC-based access control ensure all users are authorized before being granted access to the network.

Ingress/Egress Access Control Lists (ACLs) can be used to restrict access to sensitive network resources by denying packets based on L2/L3/L4 headers information. And for some services that are based on time, the product can support time-based ACL to match the requirement.

Secure Shell (SSH) encrypts network management information via Telnet providing secure network management.

RADIUS Authentication enables centralized control of the switch and restricts unauthorized users from altering the configuration of the switch.

Specifications

Item	CS6200-8G24S2Q-EI
Physical port	8 x 10/100/1000BaseT + 24 x 10GE(SFP+) + 2 x 40GE(QSFP+)
Management port	1 x RJ45 Ethernet Management port
	1x Console port
	1x USB2.0 interface
Performance	
Switching Capacity	656Gbps
Forwarding Rate	488Mpps
Jumbo Frame	16K
MAC Address	32K
ARP Table	16K
Routing Table	16K
ACL Table	3K
L3 Interface	Max 1K
Physical	
Dimension (W*H*D)	440mm x 44mm x 320mm
Relative Humidity	5%~90% non-condensing, storage 95%
Temperature	Working 0°C~50°C, storage -40°C~70°C
Power Supply	AC: 100~240VAC, 50~60Hz + 48VDC
Power Consumption	<85W
Main Features	
L1, L2 Features	IEEE802.3(10Base-T), IEEE802.3u(100Base-TX), IEEE802.3z(1000BASE-X), IEEE802.3ab(1000Base-T), IEEE802.3ae(10GBase), IEEE802.3x, IEEE802.3ak(10GBASE-CX4), IEEE 802.3ba, Auto MDI/MDIX
	Port loopback detection LLDP and LLDP-MED UDLD 802.3ad LACP, max 128 group trunks with max 8 ports for each trunk LACP load balance
	N:1 Port Mirroring RSPAN
	IEEE802.1d(STP) IEEE802.1w(RSTP) IEEE802.1s(MSTP) Root Guard BPDU Guard
	802.1Q, 4K VLAN MAC VLAN, Voice VLAN, PVLAN, Protocol VLAN, Multicast VLAN QinQ, Selective QinQ, Flexible QinQ GVRP Broadcast / Multicast / Unicast Storm Control
	IGMP v1/v2/v3 Snooping and L2 Query, IGMP Proxy ND Snooping MLDv1/v2 Snooping
	Port Security
	Flow Control: HOL, IEEE802.3x
	Bandwidth Control

L3 Features	Static Routing, RIPv1/v2, OSPFv2, BGP4 OSPFv3, BGP4+ OSPF multiple processes Policy-based routing (PBR) for IPv4 and IPv6 VRRP URPF, ECMP BFD
	DVMRP, PIM-DM, PIM-SM, PIM-SSM, Anycast RP, MSDP Static Multicast Route Multicast Receive Control Illegal Multicast Source Detect
	ARP Guard, Local ARP proxy, Proxy ARP, ARP Binding, Gratuitous ARP, ARP Limit Anti ARP/NDP Cheat, Anti ARP/NDP Scan
	DNS Client, DNS Relay
IPv6	ICMPv6, ND, DNSv6 IPv6 Policy-based Routing (PBR) IPv6 VRRPv3, IPv6 URPF, IPv6 RA RIPng, OSPFv3, BGP4+ MLD Snooping, IPv6 Multicast VLAN MLDv1/v2, PIM-SM/DM for IPv6, IPv6 Anycast RP, IPv6 ACL, IPv6 QoS
QoS	8 Queues SWRR, SP, WRR, WDRR, SWDRR Traffic Classification Based on 802.1p COS, ToS, DiffServ DSCP, ACL, port number Traffic Policing PRI Mark/Remark
ACL	IP ACL, MAC ACL, IP-MAC ACL Standard and Expanded ACL Based on source/destination IP or MAC, IP Protocol, TCP/UDP port, DSCP, ToS, IP Precedence), VLAN, Tag/Untag, CoS REDIRECT and Accounting based ACL Rules can be configured to port, VLAN Time Ranged ACL
Security	802.1x AAA Port, MAC-based authentication Accounting based on time length and traffic Guest VLAN and auto VLAN
	RADIUS for IPv4 and IPv6
	TACACS+ for IPv4 and IPv6
	MAB
DHCPv4/v6 Traffic Monitor	DHCP Server/Client for IPv4/IPv6 DHCP Relay/Option 82 DHCP Snooping/Option 82
Traffic Monitor	sFlow Traffic Analysis
Security Network Management	CLI, WEB, Telnet, SNMPv1/v2c/v3 through IPv4 and IPv6 Syslog and external Syslog Server HTTP SSL SNMP MIB, SNMP TRAP FTP/TFTP SNTP/NTP RMON 1,2,3,9 Authentication by Radius/TACACS SSH v1/v2 Dual firmware images/ Configuration files 802.3ah OAM, 802.1ag OAM
Data Center Features	VSF (Virtual Switch Framework)

Application

Core layer switch in a small campus or enterprise network

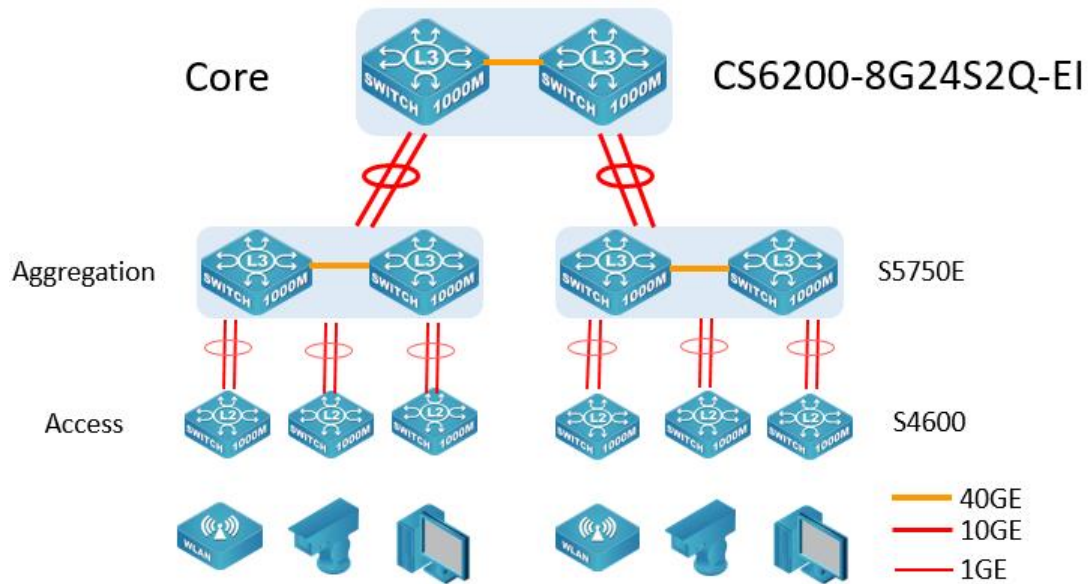

Order Information

Product	Description
CS6200-8G24S2Q-EI	40G Ethernet Routing Switch, 8 x 10/100/1000Base-T (RJ45) + 24 x 10GE (SFP+) + 2 x 40GbE (QSFP+), AC + 48VDC power supply